

ebm-papst Mulfingen GmbH & Co. KG

Bachmühle 2 · D-74673 Mulfingen

Phone +49 7938 81-0

Fax +49 7938 81-110

info1@de.ebmpapst.com

www.ebmpapst.com

Limited partnership · Headquarters Mulfingen

Amtsgericht (court of registration) Stuttgart · HRA 590344

General partner Elektrobau Mulfingen GmbH · Headquarters Mulfingen

Amtsgericht (court of registration) Stuttgart · HRB 590142

Nominal data

Type	W2G130-AA33-20	
Motor	M2G055-BD	
Phase		DC
Nominal voltage	VDC	24
Nominal voltage range	VDC	16 .. 28
Frequency	Hz	-
Method of obtaining data		fa
Speed (rpm)	min ⁻¹	3150
Power consumption	W	16
Current draw	A	0.74
Min. ambient temperature	°C	-25
Max. ambient temperature	°C	60

ml = Max. load · me = Max. efficiency · fa = Free air · cs = Customer specification · ce = Customer equipment
Subject to change



Technical description

Weight	0.9 kg
Fan size	130 mm
Rotor surface	Painted black
Blade material	Sheet steel, painted black
Fan housing material	Die-cast aluminum, painted black
Number of blades	7
Airflow direction	"V"
Direction of rotation	Counterclockwise, viewed toward rotor
Degree of protection	IP20
Insulation class	"B"
Max. permitted ambient temp. for motor (transport/storage)	+ 80 °C
Min. permitted ambient temp. for motor (transport/storage)	- 40 °C
Installation position	Any
Condensation drainage holes	None
Mode	S1
Motor bearing	Ball bearing
Technical features	- Tach output - Motor current limitation
Motor protection	Reverse polarity and locked-rotor protection
Conformity with standards	EN 60335-1
Approval	CSA C22.2 No. 113; UL 507; EAC

Product drawing

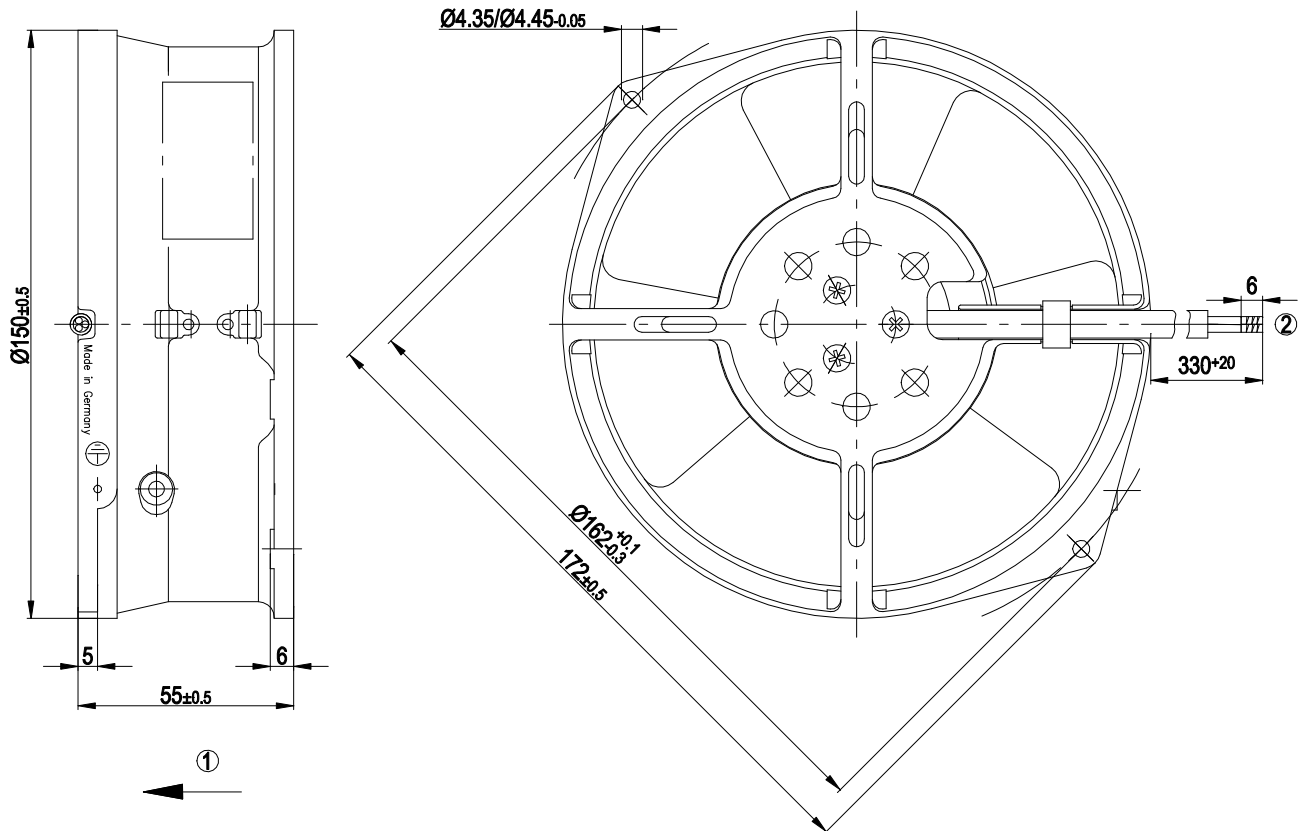

- | | |
|---|---------------------------------|
| 1 | Airflow direction "V" |
| 2 | Cable AWG20, 3x crimped splices |

EC axial compact fan

sickle-shaped blades (S series)

Connection diagram

Customer circuit

Interface

Fan/Motor

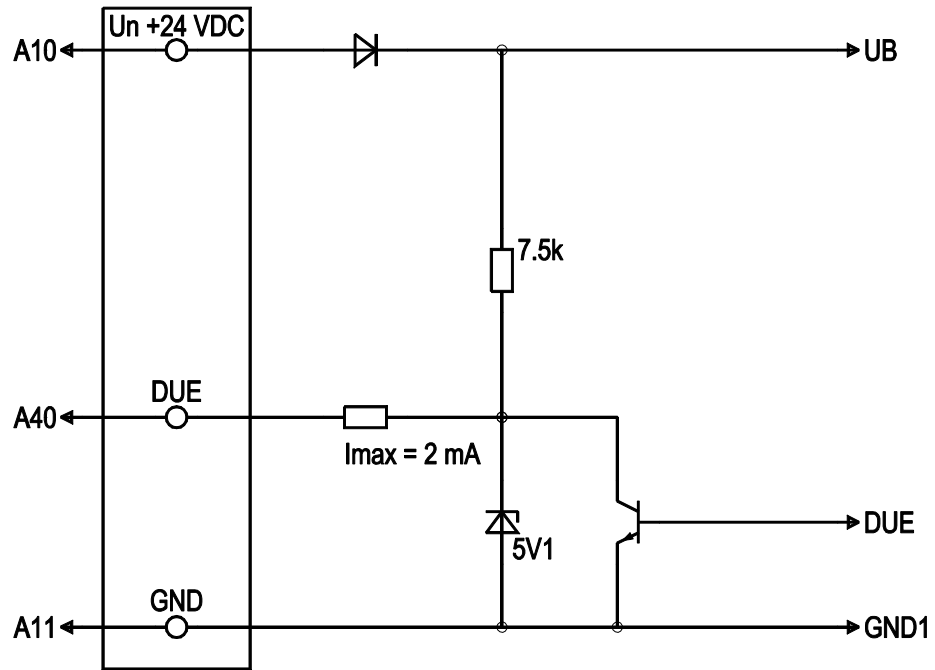

No.	Conn.	Designation	Color	Function/assignment
	A10	+24 VDC	red	Power supply 24 VDC, see nameplate for voltage range, maximum ripple 3.5%
	A40	Tach	white	Speed monitoring, 2 pulses per revolution, I _{source} max. 2 mA/optional
	A11	GND	blue	Reference ground



Curves: Air performance

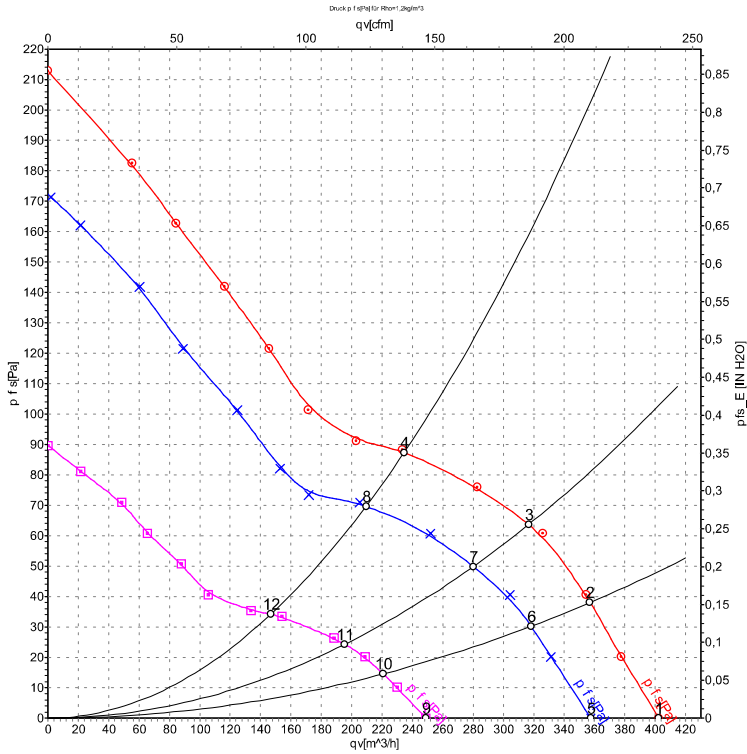

Measurement: LU-47058-1
 Measurement: LU-47057-1
 Measurement: LU-47059-1

Air performance measured according to ISO 5801 installation category A. For detailed information on the measurement setup, contact ebm-papst. Inlet sound level: Sound power level according to ISO 13347 / sound pressure level measured at 1 m distance from fan axis. The values given are valid under the specified measuring conditions and may vary due to conditions of installation. For deviations from the standard configuration, the parameters have to be checked on the installed unit.

Measured values

	U	n	P _{ed}	I	q _v	P _{fs}	q _v	P _{fs}
	V	min ⁻¹	W	A	m ³ /h	Pa	cfm	inH2O
1	28	3555	21	0.80	400	0	235	0.00
2	28	3490	22	0.82	355	38	210	0.15
3	28	3430	23	0.84	315	64	185	0.26
4	28	3400	23	0.86	235	88	140	0.35
5	24	3150	16	0.74	360	0	210	0.00
6	24	3105	17	0.75	320	30	185	0.12
7	24	3060	17	0.76	280	50	165	0.20
8	24	3040	17	0.77	210	70	125	0.28
9	16	2210	6.7	0.58	250	0	145	0.00
10	16	2180	7.0	0.59	220	15	130	0.06
11	16	2160	7.3	0.60	195	24	115	0.10
12	16	2155	7.3	0.60	145	34	85	0.14

U = Power supply · n = Speed (rpm) · P_{ed} = Power consumption · I = Current draw · q_v = Air flow · p_{fs} = Pressure increase

